

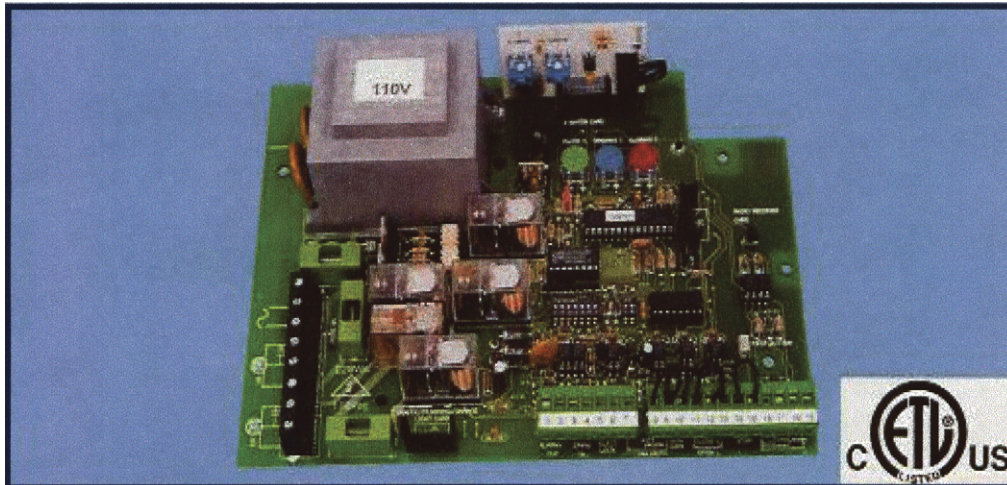

BYAN SYSTEM, INC.

413 LINDEN
LUSK, WY 82225
(800) 223-2926



G2M Control Board

Installation and Operations Manual

Specifications

Power supply	Single Phase 115V or 220V 50/60 Hz AC
Motor Power Consumption	Up to 550W or 3/4 hp
Electric Lock Output	12V DC 1A max.
Accessory Power Output	24V AC 1A max.
Input Power Fuse	2A, 250V; 5mm x 20mm tubular glass
Motor Power Fuses	6A, 250V; 5mm x 20mm tubular glass

P.O. BOX 1384

FAX (307) 334-2028

BYAN SYSTEMS, INC.
Automated Gate and Access Control Products

Table of Contents:

Board Layout	2
Description	2
Terminal Information	2
Power and Motor Run Terminal Table	3
Commercial Power Hook-Up	3
Accessory Terminal Table	4
Accessory Hook-Up	5
Timing Potentiometers	6
S1 DIP Switches; Table S1 & S1a	6
S2 DIP Switches; Table S2	7
Power and Motor Run Terminal Strip Conversion Tables	8
Accessory Terminal Strip Conversion Tables	8
12 X 10 and 20 X 16 Prewire Layouts	10
24 X 20 Prewire Layout	11
Trouble Shooting Guide	12
T2M Leaf Delay Card	14
Warranty	15

G2M Control Board Layout:

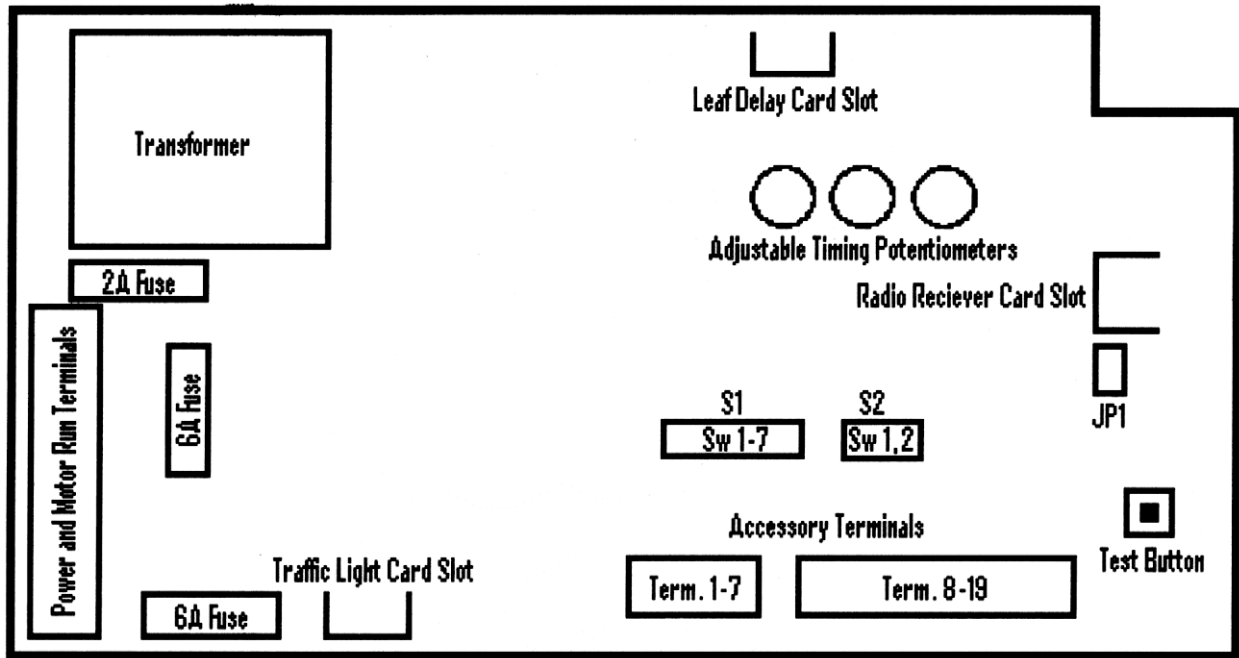

Description:

The Byan Systems G2M control board is a single phase, microprocessor controlled unit. It is capable of controlling up to two 3/4 hp 115V or 220V AC motors. Board voltage is field selectable with good soldering skills and high quality soldering tools. Three different plug-in accessory cards are available for the G2M. A leaf delay card comes standard with every board. A traffic light card and a receiver card are available separately. There are three timing potentiometers as well as nine DIP switches incorporated into the board to control different output functions.

Terminal Strips:

There are two sets of terminals on the G2M control board. The first terminal strip is the power and motor run terminal block located on the left side of the board below the transformer. This is where the incoming commercial power and the outgoing power to the operators are connected.

The second terminal strip is the accessory terminal strip. This is where all accessory connections are made.

BYAN SYSTEMS, INC.
Automated Gate and Access Control Products

Power and Motor Run Terminals

<u>Terminal Number</u>	<u>Terminal Name/Description</u>
1	Commercial Power Input Neutral (White 115V) or Hot (Black 220V)
2	Commercial Power Input Hot (Black-115V or Red-220V)
3	Motor One Close Directional (Black)
4	Motor One Open Directional (Red)
5	Motor One Common (White)
6	Motor Two Close Directional (Black)
7	Motor Two Open Directional (Red)
8	Motor Two Common (White)

Commercial Power Hook-Up*:

1. Hook up commercial power to terminals 1 & 2 of the power and motor run terminal strip.
2. Connect leads from the #1 operator to terminals 3, 4, & 5 of the power and motor run terminal strip.
3. Connect leads from the #2 operator to terminals 6, 7 & 8 of the power and motor run terminal strip.
4. Connect motor run capacitors across each set of directional motor leads (between terminals 3 & 4 and terminals 6 & 7).

*See conversion table on pg. 6 for corresponding terminal blocks in the Byan Prewires.

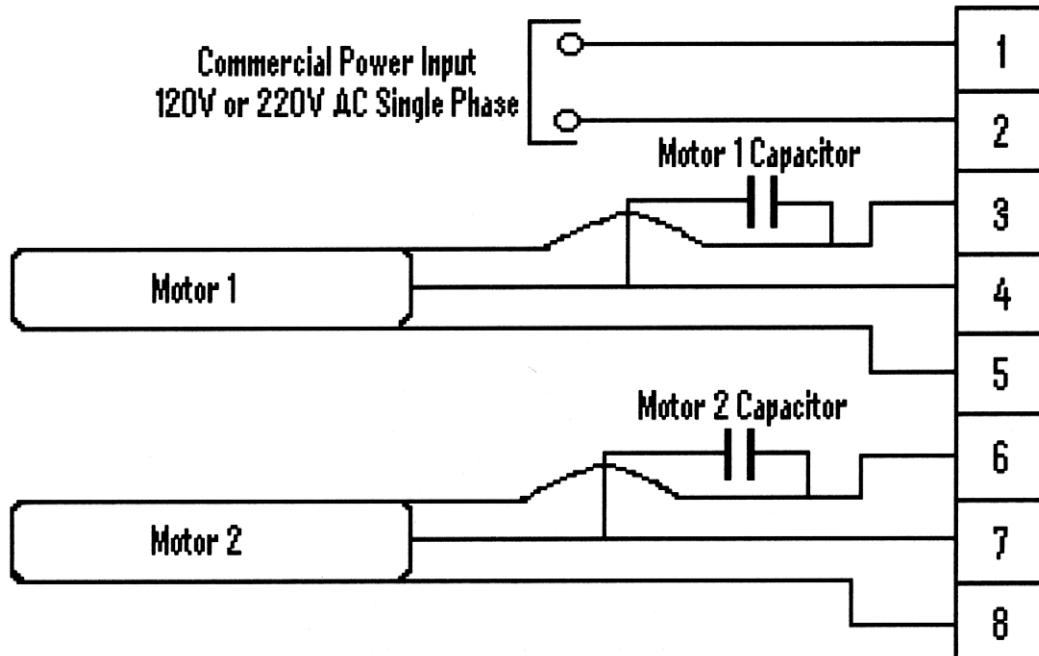

BYAN SYSTEMS, INC.

Automated Gate and Access Control Products

Accessory Terminal Table

<u>Terminal Numbers</u>	<u>Terminal Name</u>	<u>Possible Uses</u>
1 - 2	Alarm Output	These terminals allow the connection of a device to alert the user that people safe has been activated.
3 - 4	24V AC 1A Output	Power for accessories such as radio receivers, loop detectors, or anything requiring 24V AC 1A may be connected here.
5 - 6	12V DC 1A Pulsed Electric Lock Output	Magnetic or other types of lock release signals may be connected here.
7 - 9	People Safe Alarm Reset Input	A button or other N/O contact may be connected here to reset the people safe alarm output relay.
8	People Safe Input	N/C people safe devices such as sensing edges are connected here.
9	Safety Common Input	Common wires for people and car safety devices are connected here.
10	Car Safe Input	N/C car safe devices such as loop detectors and photo beams are connected here.
11	Limit Switch Common Input	If limit switches are required, the common Wires would be connected here.
12	Close Limit Switch Input	If limit switches are required, the close limit switch would be connected here.
13	Open Limit Switch Input	If limit switches are required, the open limit switch would be connected here.
14 - 15	Stop Input	A N/C device used to stop the operators such as a button may be connected here.
16	Control Function Common Input	This is where the common of devices used to open, close, or reverse the gate would be connected.
17	Close Function Input	Devices only used to close the gate such as in ground loops, buttons, or photo beams are connected here.
18	Open Function Input	Devices only used to open the gate such as in ground loops, buttons, or radio receivers are connected here.
19	Reverse Function Input	Devices used to reverse the gates direction such as in ground loops, buttons, or radio receivers are connected here.

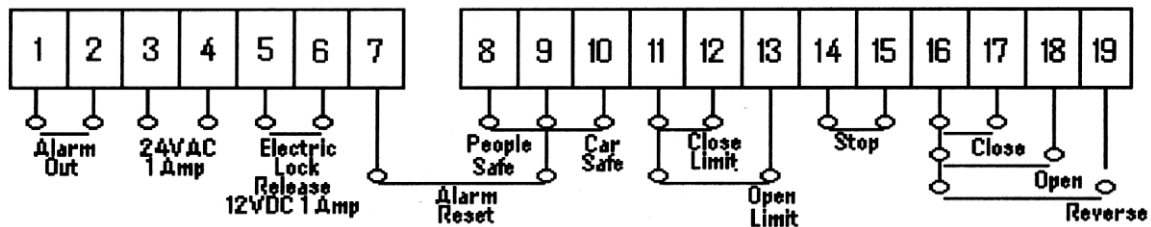

BYAN SYSTEMS, INC.

Automated Gate and Access Control Products

Accessory Hook-Ups*:

There are many accessories available that are compatible with the G2M that will give the end user different options for safety, security, and system operations. Since it would be impossible to outline all possible combinations, we will simply outline a few of the most common. Keep in mind; these instructions are specific to the brand and model most commonly used by Byan Systems. Your accessories may differ from the ones listed below. Always consult the Installation Instructions included with an accessory before connection it to any operating system.

Linear GRD 1 Radio Receiver:

1. Separate the four wires coming out of the bottom of the receiver (1 Red, 1 Black, & 2 Gray).
2. Connect the black wire to terminal 3 of the accessory terminal strip.
3. Connect the red wire to terminal 4 of the accessory terminal strip.
4. Connect one of the gray wires to terminal 16 of the accessory terminal strip.
5. Connect the other gray wire to terminal 18 of the accessory terminal strip for open only or terminal 19 for use as a reversing device.
6. If an external antenna is required, locate the bulk head connector supplied with the receiver.
7. Drill 1 3/8" hole in the enclosure where you would like to mount the antenna.
8. Install the bulk head connector in the hole using the hardware included with the receiver. Be sure to use thread locking compound in the threads when installing the connector.
9. Connect the supplied coax between the receiver and the bulk head connector and attach the antenna to the outside of the connector.

Mag-Lock Relay Using Idec SH2B-05 Base w/RH2B-UDC12V Relay:

1. Connect terminal 14 on the relay base to terminal 6 of the accessory terminal strip.
2. Connect terminal 13 on the relay base to terminal 5 of the accessory terminal strip.
3. Connect Neutral or Ground from the mag-lock transformer directly to the mag-lock.
4. Connect Hot from the mag-lock transformer to terminal 9 of the relay base.
5. Connect terminal 1 on the relay base to the mag-lock.
- 6.

Loop Detector Using Idec SR3P-06 Base w/EDI LMA1100-120 Loop Detector:

1. Connect terminals 7 & 8 to the in ground loop leads.
2. Connect 120V AC Neutral to terminal 2 of the detector base.
3. Connect 120V AC Hot to terminal 1 of the detector base.
4. Connect desired signal wires from the detector base to the accessory terminal strip of the G2M.

Shadow: (instruction referencing relay refer to Idec SH2B-05 relay base and RH2B-UAC110-120 relay)

1. Connect terminal 9 of the relay base to terminal 5 of the detector base.
2. Connect terminal 5 of the detector base to terminal 9 of the accessory terminal strip.

BYAN SYSTEMS, INC.

Automated Gate and Access Control Products

3. Connect terminal 5 of the relay base to terminal 10 of the detector base.
4. Connect terminal 10 of the detector base to terminal 10 of the accessory terminal strip.

Safety:

1. Connect terminal 5 of the detector base to terminal 9 of the accessory terminal strip.
2. Connect terminal 10 on the detector base to terminal 10 of the accessory terminal strip.

Free Exit:

1. Connect terminal 5 on the detector base to terminal 16 of the accessory terminal strip.
2. Connect terminal 6 of the detector base to terminal 18 of the accessory terminal strip.

*See conversion tables on pg. 7 for corresponding terminal blacks in the Byan Prewires.

Characteristics:

Adjustable Timing Potentiometers:

Color	Description	Minimum Time	Maximum Time
Green	Automatic Closing Timer	1 sec.	1 min. 30 sec.
Blue	Opening Timer	3 sec.	30 sec. *
Red	Closing Timer	3 sec.	30 sec. *

*With dip switch 1 on S2 turned on, maximum open and close times are doubled to 1 minute.

DIP Switches

Table S1

Number	Optional Name	Option Description
1	Reversing Stroke Function	When turned on, the operators will first close for 1 sec. before opening.
2	Step-by-step Function	When turned on, each movement of the operators by any reverse input will require an individual input (deactivates automatic re-open function).
3	Automatic Closing Function	When turned on, the operators will close by the time set with the yellow timing potentiometer.
4	Reverse Button Inoperative During Opening	When turned on, any reverse input is deactivated during the open cycle.
5	Closing Order by Car Safety Contact	With DIP switch 3 off and 5 turned on, the operators will close as soon as the car safety contacts are cleared.
6	*See Note Below	-----
7	Car Safety Contact Operative During Opening	When turned on, car safety contacts are active during the open and close cycles.

*The function of DIP switch 6 is changed by the position of the jumper (JP1) located below the radio receiver card (J3). Table S1a describes the function of DIP switch 6 and its relation to JP1

BYAN SYSTEMS, INC.

Automated Gate and Access Control Products

Table S1a

	JP1 Open	JP1 Closed
DIP Switch 6 On	When power is applied to the board, operators will automatically do a closing function.	The traffic light card will act as a flashing light card (upper relay), and a garage light card (lower relay).
DIP Switch 6 Off	When power is applied to the board, the operators will automatically do an opening function.	The traffic light card relays will act as a green light (upper relay) and a red light (lower relay).

Table S2

Number	Option Name	Option Description
1	Doubling Time	When turned on, maximum opening and closing time is extended from 30 seconds to 1 minute and maximum pause time is extended from 45 seconds to 1 minute 30 seconds.
2	Repositioning the Door	When turned on, the operators will cycle in the last direction of operation for 2 seconds every hour.

G2M to Byan Prewire Terminal Conversion Tables*:

G2M Power and Motor Terminal Strip to Byan 12 x 10 Prewire

<u>G2M Terminal Number</u>	<u>12 X 10 Terminal Strip</u>	<u>Terminal Number</u>
1	TB1	3 (115V) 2 (220V)
2	TB1	2 (115V) 1 (220V)
3	TB2	1
4	TB2	2
5	TB2	3
6	TB2	4
7	TB2	5
8	TB2	6

G2M Power and Motor Terminal Strip to Byan 20 x 16 Prewire

<u>G2M Terminal Number</u>	<u>20 X 16 Terminal Strip</u>	<u>Terminal Number</u>
1	TB1	3(115V) 2 (220V)
2	TB1	2 (115V) 1 (220V)
3	TB3	2
4	TB3	3
5	TB3	4
6	TB3	6
7	TB3	7
8	TB3	8

BYAN SYSTEMS, INC.

Automated Gate and Access Control Products

G2M Power and Motor Terminal Strip to Byan 24 x 20 Prewire

<u>G2M Terminal Number</u>	<u>24 x 20 Terminal Strip</u>	<u>Terminal Number</u>
1	TB1	3(115V) 2 (220V)
2	TB1	2 (115V) 1 (220V)
3	TB3, TB4	2
4	TB3, TB4	3
5	TB3, TB4	4
6	TB3, TB4	6
7	TB3, TB4	7
8	TB3, TB4	8

G2M Power and Motor Terminal Strip to Byan 30 x 24 Prewire

<u>G2M Terminal Number</u>	<u>24 x 20 Terminal Strip</u>	<u>Terminal Number</u>
1	TB1	3(115V) 2 (220V)
2	TB1	2 (115V) 1 (220V)
3	TB4, TB5	2
4	TB4, TB5	3
5	TB4, TB5	4
6	TB4, TB5	6
7	TB4, TB5	7
8	TB4, TB5	8

G2M Accessory Terminal Strip to Byan 12 x 10 Prewire

<u>G2M Terminal Number</u>	<u>12 x 10 Terminal Strip</u>	<u>Terminal Number</u>
3	TB3	1
4	TB3	2
8	TB3	3
9	TB3	4
10	TB3	5
16	TB3	6
18	TB3	7
19	TB3	8

G2M Accessory Terminal Strip to Byan 20 x 16 Prewire

<u>G2M Terminal Number</u>	<u>20 x 16 Terminal Strip</u>	<u>Terminal Number</u>
3	TB4	1
4	TB4	2
8	TB4	3
9	TB4	4
10	TB4	5
16	TB4	6
18	TB4	7
19	TB4	8

BYAN SYSTEMS, INC.

Automated Gate and Access Control Products

G2M Accessory Terminal Strip to Byan 24 x 20 Prewire

<u>G2M Terminal Number</u>	<u>12 x 10 Terminal Strip</u>	<u>Terminal Number</u>
3	TB5, TB7	1
4	TB5, TB7	2
8	TB5, TB7	3
9	TB5, TB7	4
10	TB5, TB7	5
16	TB5, TB7	6
18	TB5, TB7	7
19	TB5, TB7	8

G2M Accessory Terminal Strip to Byan 30 x 24 Prewire

<u>G2M Terminal Number</u>	<u>12 x 10 Terminal Strip</u>	<u>Terminal Number</u>
3	TB6, TB8	1
4	TB6, TB8	2
8	TB6, TB8	3
9	TB6, TB8	4
10	TB6, TB8	5
16	TB6, TB8	6
18	TB6, TB8	7
19	TB6, TB8	8

*See Prewire layouts on pg. 8 & 9 for reference.

BYAN SYSTEMS, INC.

Automated Gate and Access Control Products

Byan Systems 12 x 10 & 20 x 16 Prewire Layouts:

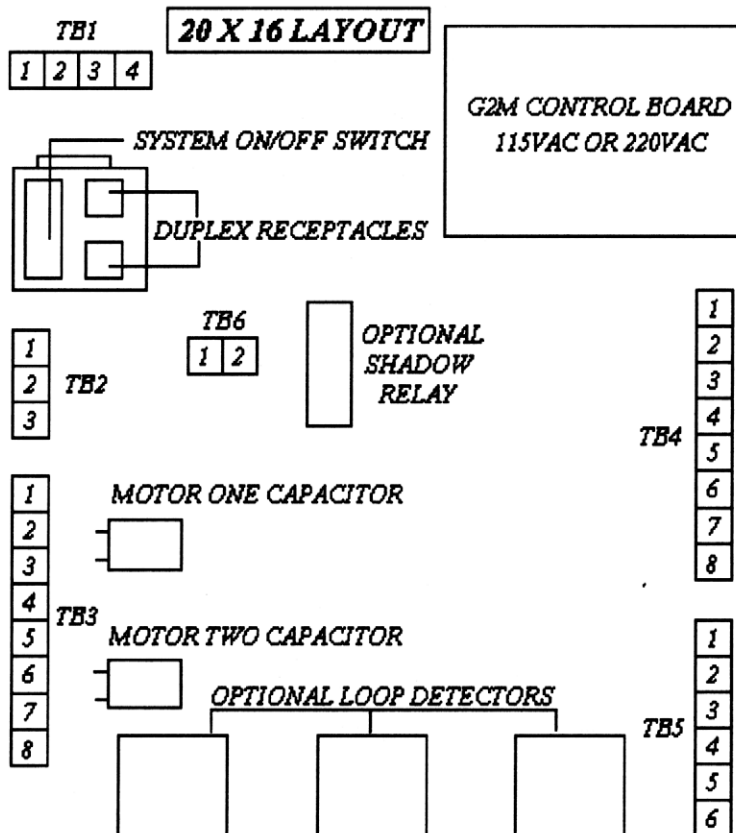
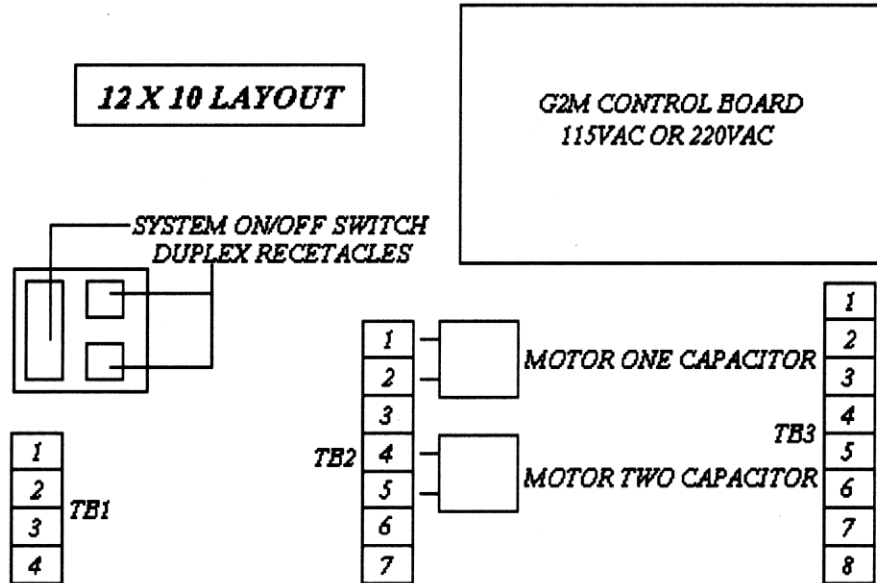

BYAN SYSTEMS, INC.

Automated Gate and Access Control Products

Byan Systems 24 x 20 Prewire Layout:

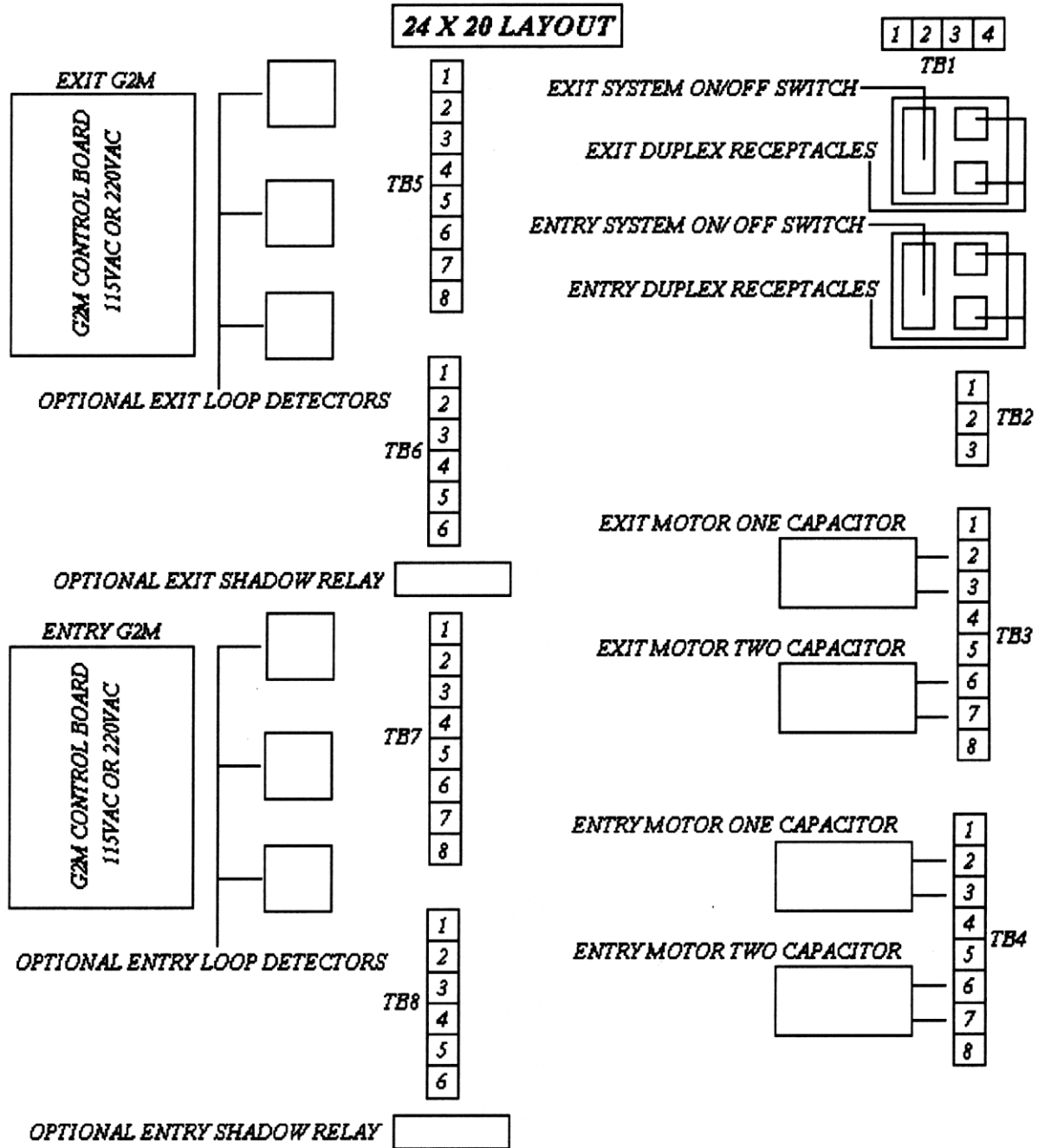

BYAN SYSTEMS, INC.

Automated Gate and Access Control Products

Trouble Shooting Guide:

<u>Symptom</u>	<u>Possible Cause</u>	<u>Possible Solutions</u>
Board will not power up	Power not connected, switch in prewire not turned on, board voltage of board incorrect, blown incoming power fuse	Ensure all connections are made and are tight, make sure switch in prewire is on, make sure board voltage matches incoming power, check 2A fuse on the G2M
Board is powered up but won't function	Jumper wires in accessory terminal loose/missing, safety device malfunctioning, blown operator fuse	Check all jumper wires for location and make sure they are tight, make sure safety devices are clear of obstruction and connected properly (the G2M uses N/C safety contacts), check 6A fuses on the G2M
Operations will not open or close fully	Timers not adjusted properly, dip switches are in the wrong position	Timers should be adjusted so operator pistons bottom out completely then run for an additional 3 – 5 seconds, make sure all dip switches are in the desired location and making good contact
Operators run, but there is no piston movement	Capacitor bad or not hooked up, bypass screw on operator backed out	Check that capacitors are hooked up, if one is suspect, switch capacitors and see if the problem follows the capacitor, make sure bypass screw is screwed in and snug
Safety devices connected properly but not functioning properly	Jumpers in term. 8, 9 & 10 are still in, safety device is malfunctioning	If car safe is used, make sure that the jumper between accessory terminals 9 & 10 is removed, for people safe, remove jumper between accessory terminals 8 & 9, make sure the safety device is connected and working properly
Radio receiver will only open the gate	Radio receiver is wired incorrectly	If the receiver is to be used as a reversing device, it must be wired across accessory terminals 16 & 19
Free exit probe not working	Probe is malfunctioning, probe is wired incorrectly	Make sure probe is working properly and is connected correctly, probe's N/O contacts must be connected across accessory terminals 16 & 18, if the probe uses 24V AC for power, it can be connected to accessory terminals 3 & 4
Operators running the wrong direction	Directional wires switched	Reverse the black and red directional wires either at the operator or at the board

If at any time you have a question concerning G2M control board, call 1-800-223-2926 for technical support.

T2M Leaf Delay Card

Description:

The T2M Leaf Delay Card will control the opening and closing of the second leaf in a two-leaf gate system. With the card installed and the potentiometers adjusted, the first gate leaf will open first followed by the second when an open command is issued. When a close command is issued, the second leaf will close first followed by the first leaf. There are two adjustable potentiometers on the card. The open delay timer sets the delay between the opening of the first leaf and the opening of the second leaf. The close delay timer set the delay between the closing of the second leaf and the closing of the first leaf. There are also inputs on the card for open and close limit switches for the second leaf if limit switches are required.

Adjustable Timers:

<u>Timer Description</u>	<u>Minimum Delay</u>	<u>Maximum Delay</u>
Open Timer (Left)	0 Seconds	15 Seconds
Close Timer (Right)	0 Seconds	15 Seconds

Board Terminals (Numbered bottom to top):

1. Motor Two Limit Switch Common
2. N/C Motor Two Close Limit Switch
3. N/C Motor Two Open Limit Switch

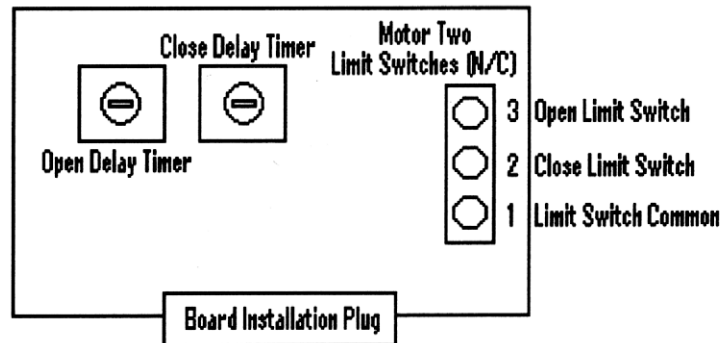

Installation Instructions:

1. To install the leaf delay card, simply plug it into the card slot marked “2 Motor Card” on the G2M.

BYAN SYSTEMS, INC.

Automated Gate and Access Control Products

Adjustment Procedure:

1. To set the amount of delay between the first leaf opening and the second leaf opening, turn the open delay time (left timer) with a small screwdriver. To increase the open delay, turn the timer counterclockwise. To decrease the open delay, turn the delay timer clockwise.
2. To set the amount of delay between the second leaf closing and the first leaf closing, turn the close delay timer (right timer) with a small screwdriver. To increase the close delay, turn the timer counterclockwise. To decrease the close delay, turn the timer clockwise.

BYAN SYSTEMS, INC.

Automated Gate and Access Control Products

FOUR-YEAR LIMITED WARRANTY

This warranty pertains only to products manufactured for/or by **Byan Systems, Inc.** for gate operating systems, accessories, and equipment. These products are warranted against all defective material for forty-eight months from the date of sale.

Defective material returned must be prepaid and accompanied by a **Byan Systems, Inc.** return authorization number within the warranty period for repair or replacement at **Byan Systems, Inc.** option. **Byan Systems, Inc.** will return warranted item freight prepaid ground service via **U.P.S.**

The warranty extends only to wholesale customers who buy direct from **Byan Systems, Inc.** through normal distributor channels. **Byan Systems, Inc.** does not warranty its products to the end user/consumer. Consumers should inquire from their selling dealer as to the nature and extent of the dealer's warranty, if any. There are no obligations or liabilities on the part of **Byan Systems, Inc.** for consequential damages arising out of or in connection with the use or performance of these products or other indirect damages with respect to loss of property, revenue or profit, cost of removal, original installation or reinstallation.

Warranty will be considered void if damage or malfunction was due to improper, inadequate or negligent installation or use of improper power source, or damage was caused by fire, flood, lightning, electrical power surge, explosion, windstorm or hail, aircraft or vehicles, vandalism, riot or civil commotion, or acts of god. All implied warranties for fitness are limited in duration to forty-eight months from date of sale. Some states do not allow how long an implied warranty lasts, so this limitation may not apply to you. This warranty by **Byan Systems, Inc.** is in lieu of all warranties expressed or implied.

Product delivery time is subject to availability. **Byan Systems, Inc.** is not responsible for any damages caused by delays in shipping or product availability.